

**elumatec<sup>®</sup>**

You have profile - we will work on it !

elumatec GmbH & Co. KG - Pinacher Straße 61 - D 75417 Mühlacker - Lomersheim  
Tel +49 (0) 7041 14-0 - Fax +49 (0) 7041 14-280 - mail@elumatec.com - www.elumatec.com

**SBZ 600+**



# Profile machining centres

You have profile - we will work on it !

# PVC

We offer the modul

You c

SBZ 600+



es for the efficient processing of your profiles !

Choose the working direction - from left to right or from right to left !

2

3

### Profile machining centres SBZ L++

- The profile machining centres SBZ 608, SBZ 609, SBZ 610, SBZ 615 and SBZ 620 are modular designed machining centres which enable efficient automation solutions for every need thanks to different execution levels. The different operations which are independent from the profile system (without counter blocks) can be fully automatically processed in PVC profiles with or without steel reinforcement.
- Thanks to the modular design of the machining centres all requirements regarding the machine's configuration can be considered - this refers to both the number of operations and output required. The machining centres are built in a way to ensure that the greatest possible number of working operations are transferred from manual to automatic processing.

### [ Description of the stations ]

#### Profile loading station with magazine to in-feed profiles

- Pre-loading of max. 10 profile bars. Robust and vibration-free steel welded construction

#### Routing and drilling station for PVC

- A tool support with a capacity of up to 30 processing units enables the processing of different profiles without change-over time. Superior drilling and routing results can be achieved thanks to a special design

#### Transfer unit with buffer function

- The link for even more efficiency

#### Sawing station

- Versatile, precise and fast. Depending on the requirement a 3- or 5-bladed sawing unit is available

#### Off-loading station

- Save even more time - elumatec also optimizes the final stage

#### Control unit

- If manual, by barcode scanner, diskette, CD-ROM, USB or network - elumatec machines are suitable for all kinds of data input

As individual as your requirement !

# Profile machining centres

You have profile - we will work on it !

## Profile machining centre SBZ 608

- Flexible routing, drilling and screw fixing
- Optimum access to automation in conjunction with a pre-existing double mitre saw or with a cutting centre
- Automatic processing of PVC profiles with or without reinforcement is possible independent from the profile
- Depending on the profile structure and the required operations up to 110 window units per 8 hours are possible. We are pleased to work out a capacity calculation according to your specifications
- Flexible working process according to your individual requirement - from left to right or right to left

### [ Technical information ]

- 11 - 17 routing and drilling units are available for all necessary operations on window and door profiles
- 2 reinforcement screw driver systems for processing of PVC and steel reinforced profiles for the production of windows and doors
- For further information please see individual catalogue

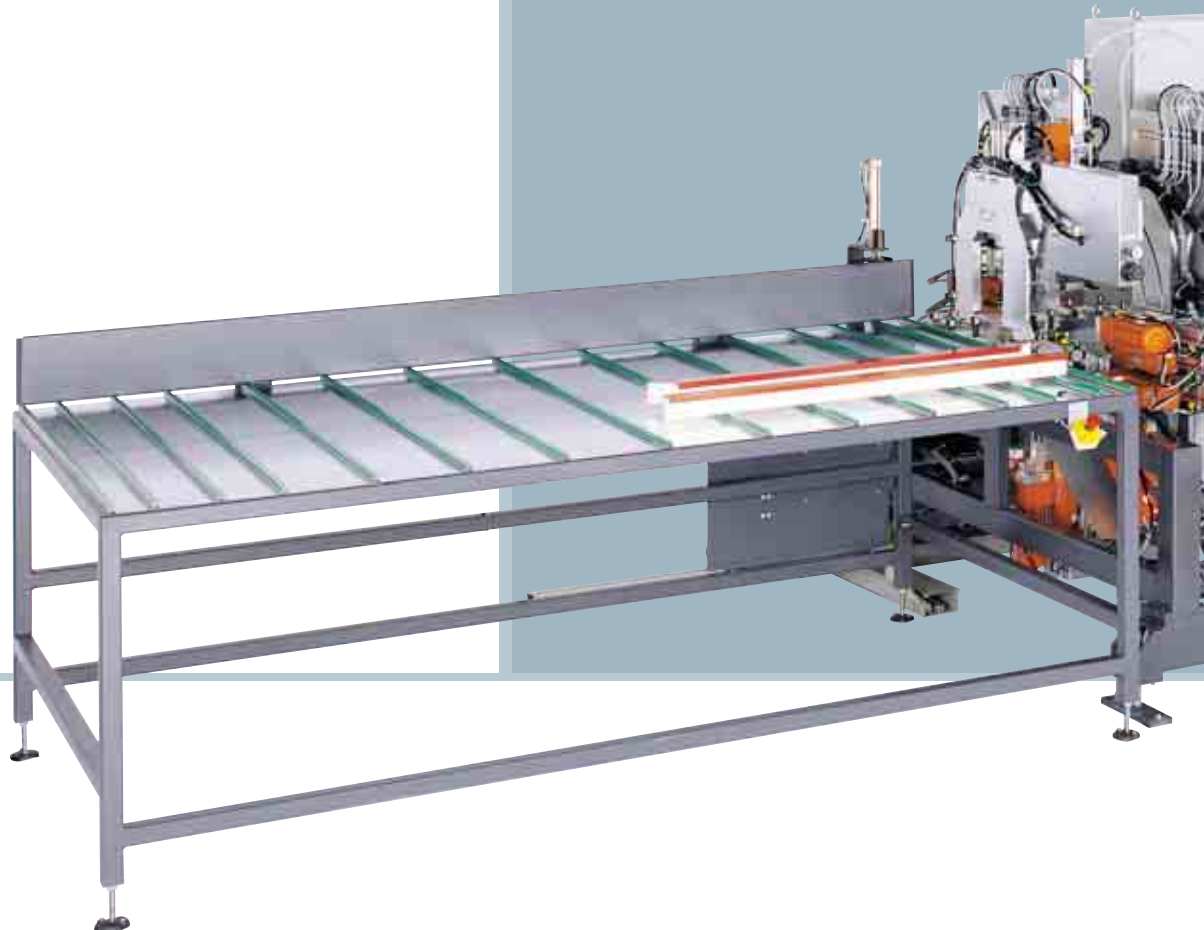

SBZ 600+



4

5



[ SBZ 608 ]

# Profile machining centres

You have profile - we will work on it !

SBZ 600+

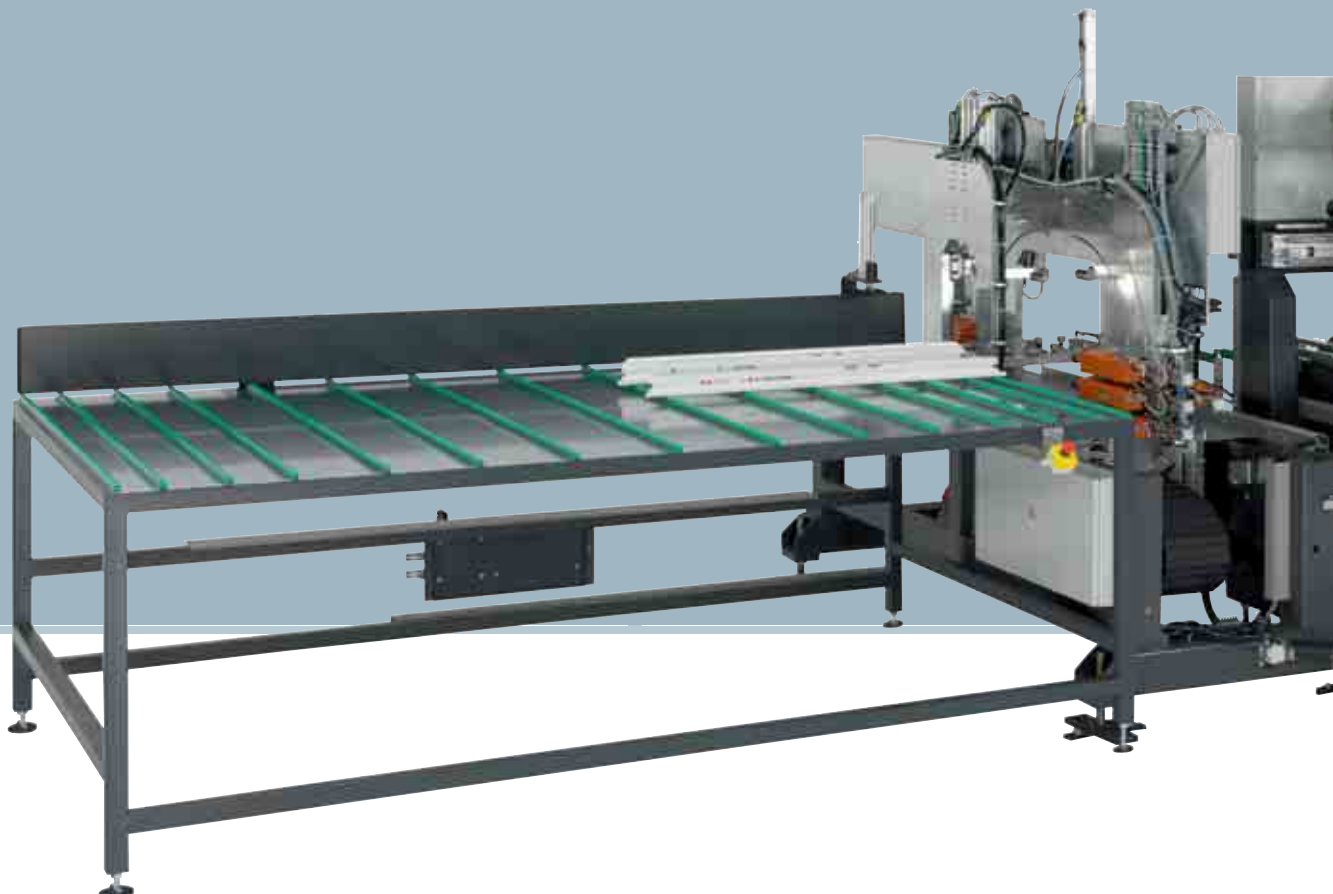



## Profile machining centre SBZ 609

- Flexible start with superior efficiency
- Automated screwing, routing and drilling in conjunction with a pre-installed sawing unit
- Special innovation: Patented rotating screw driver on a pre-installed screw fixing station enables even a higher processing speed by means of simultaneous screwing
- Depending on the profile structure and the number of operations required up to 150 window units can be produced in 8 hours. We are pleased to work out a capacity calculation according to your specifications
- Flexible working process according to your individual requirement - from left to right or right to left

### [ Technical information ]

- 11 - 30 routing and drilling units are available for all necessary operations on window and door profiles
- 1 pre-installed rotating reinforced screw fixing unit for simultaneous screwing of steel reinforcement
- For further information please see individual catalogue



[ SBZ 609 ]

# Profile machining centres

You have profile - we will work on it !

## Profile machining centre SBZ 610

- The all-round talent: Application as fast automatic saw or machining centre - you have the choice
- Maximum individualization thanks to modular design
- Processing of profiles with or without steel reinforcement is possible
- In the case of complete profile processing the sawing operation and processing of profiles are carried out on two different work stations using a buffer conveyor - this increases capacity
- Depending on the profile structure and the number of operations required up to 160 window units can be produced in 8 hours. We are pleased to work out a capacity calculation according to your specifications
- Flexible working process according to your individual requirement - from left to right or right to left

### [ Technical information ]

- Operation units for processing of PVC profiles
- 3-bladed sawing unit (45°/45°/90° front) or 5-bladed sawing unit (45°/45°/90° front/45°rear)
- Operation units for processing of PVC profiles and profiles with steel reinforcement
- For further information please see individual catalogue



SBZ 600+







# Profile machining centres

You have profile - we will work on it !

## Profile machining centre SBZ 615

- The rapid processing wonder, optimised for profiles without steel reinforcement
- Designed for maximum processing capacity at highest quality level
- Modular design either as automatic saw or as complete machining centre
- The profile bars are buffered in total length after passing through the work stations to be cut afterwards - therefore highest possible output up to 240 window units can be produced in 8 hours. We are pleased to work out a capacity calculation according to your specifications
- Flexible working process according to your individual requirement - from left to right or right to left
- [ [Technical information](#) ]
- Operation units for processing of PVC profiles
- 3-bladed sawing unit (45°/45°/90° front) or 5-bladed sawing unit (45°/45°/90° front/45° rear)
- For further information please see individual catalogue

SBZ 600+





10

11



[ SBZ 615/23 + special accessories ]

# Profile machining centres

You have profile - we will work on it !



SBZ 600+



## Profile machining centre SBZ 620

- The expanding solution for maximum capacity
- Based on the proven sawing centre SBZ 610 and the recently developed machining centre SBZ 609
- Distribution of the high cutting capacity to up to 3 linked subsequent machining centres of the series SBZ 609
- Modular enhancement and integration of transfer units enables extension to a maximum of up to 3 working stations after the saw
- Production extension is possible step by step because each individual machine has its own control system and the linked machines communicate interactively without host computer

### [ Technical information ]

- Depending on the working module, 11 - 30 routing and drilling units are available for all necessary operations on window and door profiles
- Depending on the working module, 2 pre-installed rotating reinforcement screw fixing units are available for simultaneous screwing of steel reinforcement
- 3-bladed sawing unit (45°/45°/90° front) or
- 5-bladed sawing unit (45°/45°/90° front/45°rear)
- For further information please see individual catalogue



12

13



[ SBZ 620 with 2 stations ]

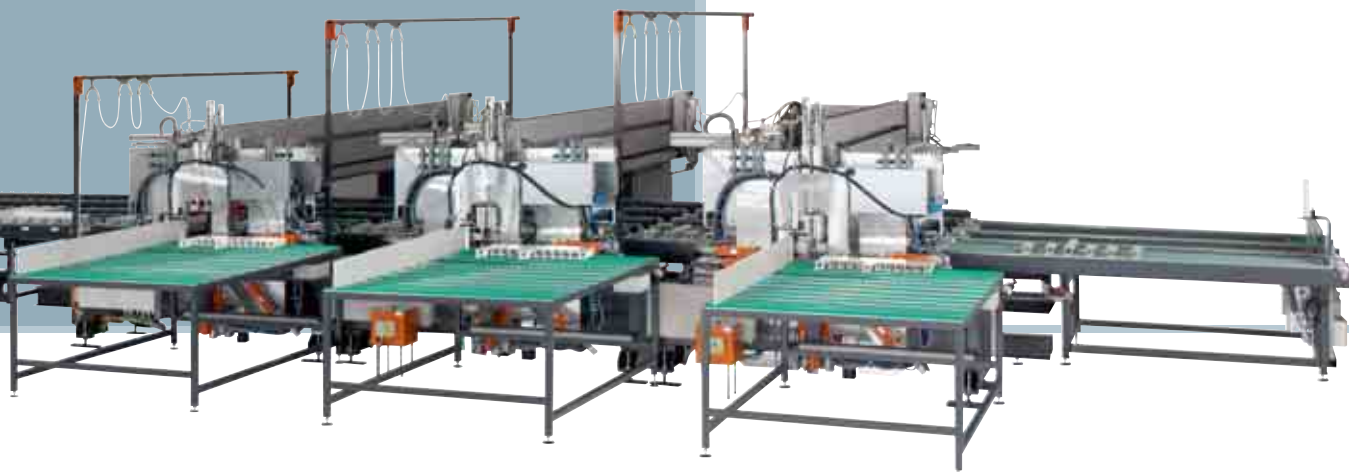

[ SBZ 620 with 3 stations ]